

PERSPECTIVE

01
| 06-01

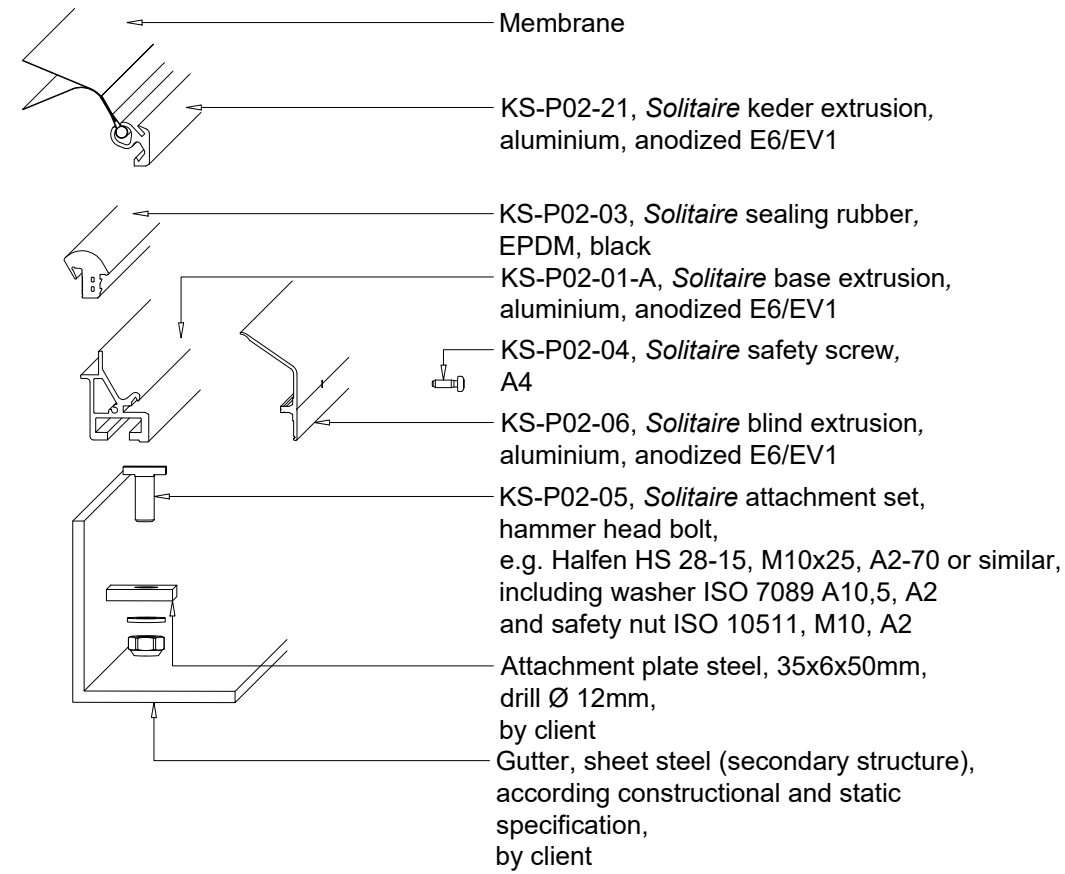

SECTION

01
| 06-01

SCALE 1:1

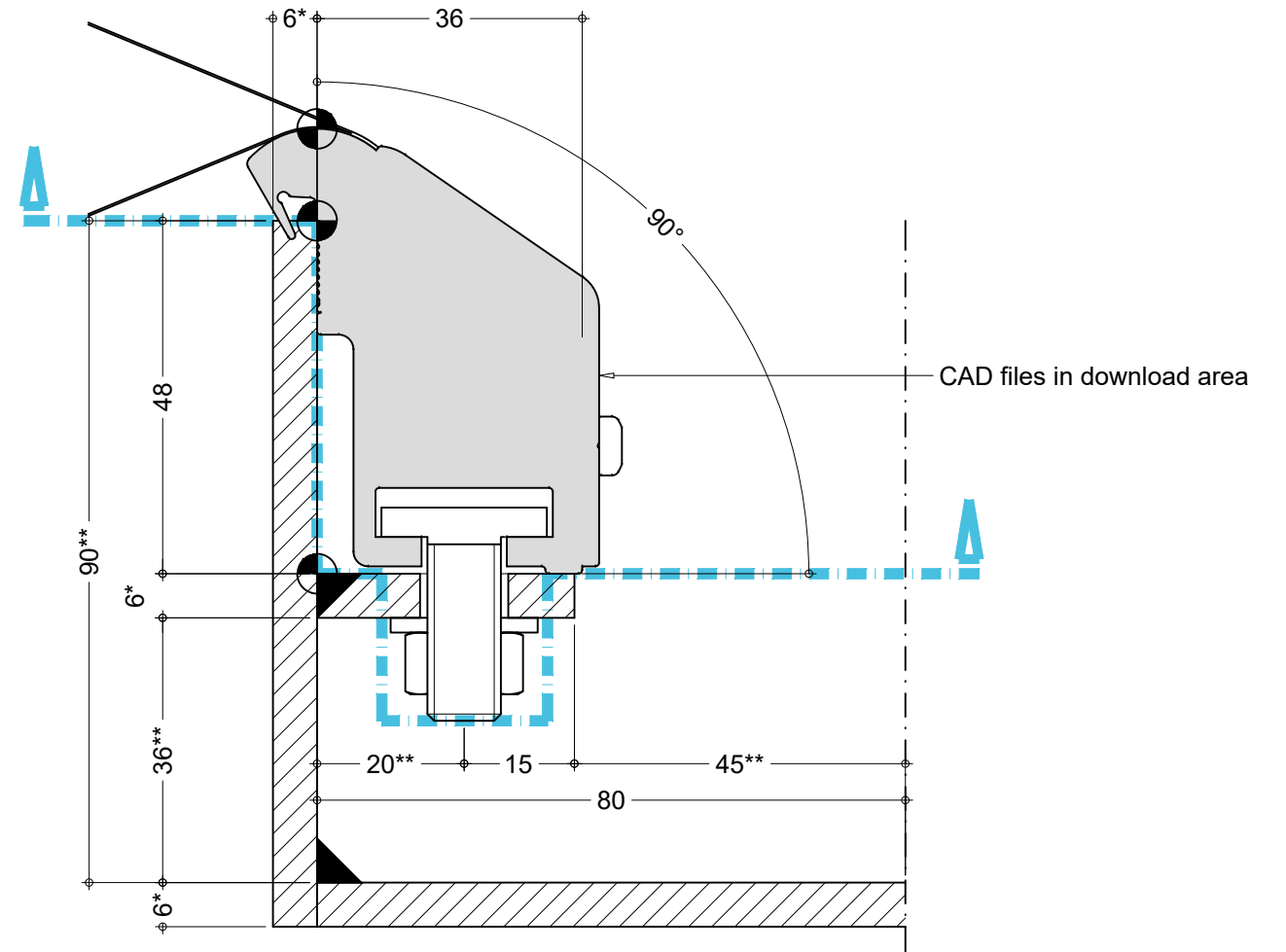

- * Thickness of bracket acc. statical requirements
- ** Structural lower limit

Notes for steel structure:

- welding seam steel structure and steel bracket as HV-seam (no collision with base extrusion)!
- zinc bumps have to be removed, at all edges and drills of the steel structure in contact with the clamping system!
- to guarantee a sufficient contact pressure between sealing rubber and gutter, the vertical gutter plate has to be fabricated even and without any offsets!

PERSPECTIVE

02
| 06-01

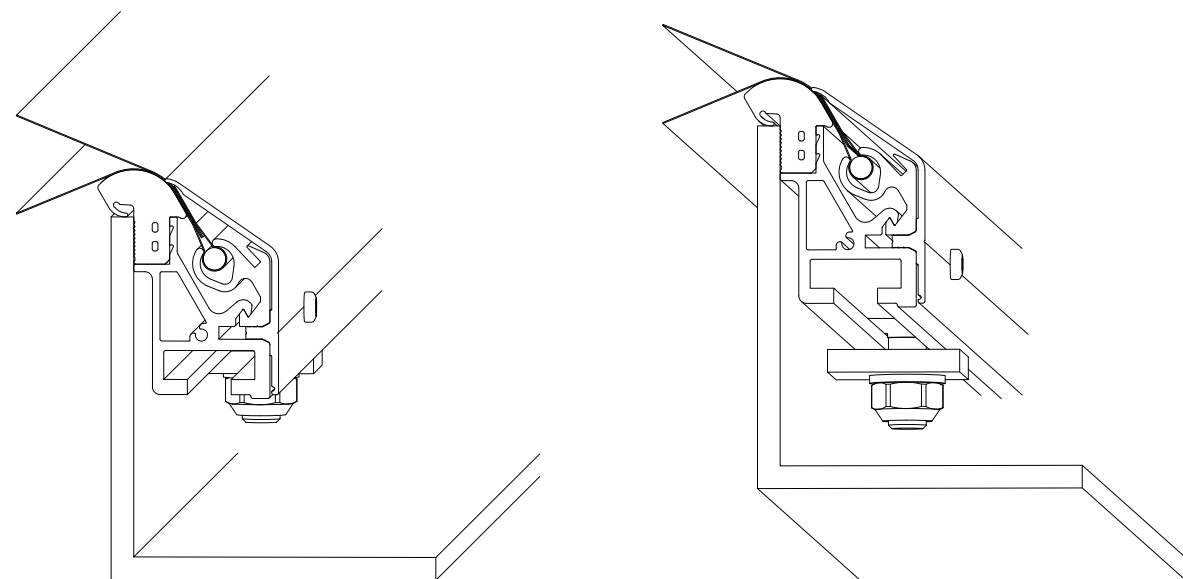

Service of konstrukt AG

 konstruct AG Am Rossacker 9, 83022 Rosenheim, Germany www.konstrukt-ag.com / info@konstrukt-ag.com	Drawn AW	Approved MJ	Date 2020-10-09	DIN A3	Rev. 0
	Drawing Name Overview Drawing				Proj. No. KS-P02
Project KS-P02, System Solitaire					
Rev.	Date	by	Revision		

Privacy & Copyright
 - This drawing and its contents is the intellectual property of the konstrukt AG and thus legally protected! Any use, publication, reproduction, revision, or transfer to third parties requires the written approval of the konstrukt AG.
 - Drawings in PDF format are valid only dated and proved.